



DOORAS
FIRE FIGHTING EQUIPMENT



DRS 8100 SERIES

www.dooras.com

DRS 8100 SERIES



DRS 8100

INTERNAL MATERIALS

- Water Supplied from Center, Corrosion Resistant Reel, TS-EN 671-1 / CE Certified
- Semi-Hard Fire Hose with round section, TS EN 694 Certificated
- Interconnection Hose (Unbreakable Type) Providing Water Passage between Valve and Reel Center
- 2"x 1" Reduction (Aluminum - Storz Type) TS 12258 Certificated
- With Jet, Spray and Off positions and Nozzle according to UL-FM and DIN / EN 671-1
- Reel Rim Phosphate Coating, Completely Electrostatic Powder Painted. (Red)
- Reel Carrier Console System (manufactured from 1.5mm DKP sheet metal material)

PRODUCT TECHNICAL SPECIFICATIONS

- Rubber Filled Wheel (not affected by temperature differences, not de-pressurized)
- Chassis (Completely made of 2mm HRP sheet metal)
- Chassis is Completely Painted with Ral 9005 Black Electrostatic Powder.
- Reel Carrier System and Rims Completely Red Electrostatic Powder Painted.
- Convenient Chassis and Wheel Group Suitable for Rough Terrain
- Products are shipped with cardboard packaging after tested hundred percent.
- Optional, Completely Galvanized or Completely Stainless CrNi Material Options are available.

DRS 8100 FIRE HOSE TROLLEY WITH SEMI-RIGID HOSE

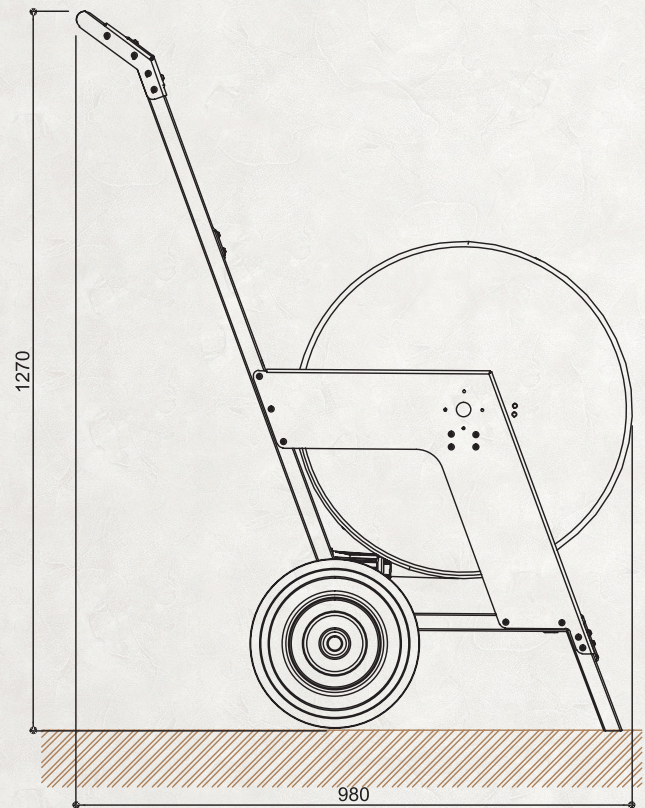
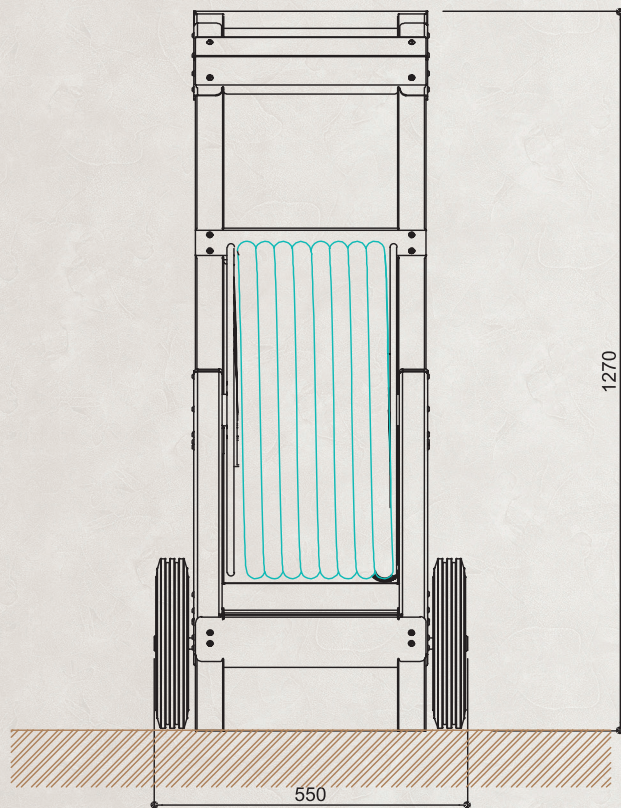

MOBILE

MODEL	PRODUCT DESCRIPTION	PRODUCT TYPE	PRODUCT DIMENSIONS (mm)
1" Semi Hard Hose	DRS8140.1	MOBILE	550x1270x980
	DRS8160.1		550x1270x980

DOORAS A.Ş. reserves the right to make modifications on the products without notification.





DOORAS
FIRE FIGHTING EQUIPMENT

**Fire is like a cancer cell,
effective first intervention can save life.**

Fire Cabinets are the most effective and fast first intervention vehicles to prevent small sparks from turning into fire.